

Manual

ALFA 77-PI MIN/MAX 24Vac

Low pressure pressostat

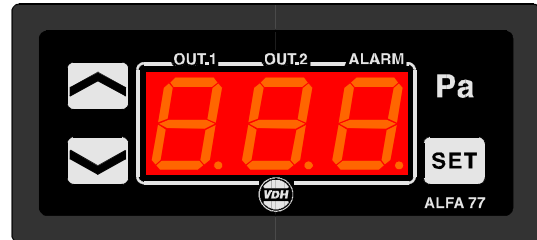

VDH doc. 080307

Version: v1.0

Date: 27-02-2008

Software: ALFA77-PI Pa

File: Do012302.WP8

Range: -99/+999 Pa

* Description.

The **ALFA 77-PI** is a Pressostat with a 0-10Vdc PI-output and two alarm relay functions.

* Installation.

On the connection diagram is shown how to connect the pressure sensor, power supply, PI output and relays. As soon as you connect the **ALFA 77-PI** to the power supply the self test will be started automatically. After this test the measured pressure will appear in the display.

* Control.

The **ALFA 77-PI** Pressostat can be controlled by four push buttons on the front:

- SET** - view / change the setpoints.
- UP** - increase a setpoint.
- DOWN** - decrease a setpoint.
- Pa** - hidden button under the Pa text.

* Viewing and changing the setpoint.

By pressing the **SET** button the setpoint appears in the display. At the same time the most right decimal point will blink, indicating the setpoint is being displayed. Release the **SET** button. Now push the **SET** key again together with the **UP** or **DOWN** keys to change the setpoint. A few seconds after releasing the keys the measured temperature shows again in the display.

* Status of the Relays.

By pushing the **Pa** key the three digits will give the status of the two relays and the PI-output. By this 0 means off and 1 means on for both relays. The code 010 means that relays 1(out.1) is off and relays 2(out.2) is on. To view the actual percentage from the PI-output (0-10Vdc) you have to push the **Up** key. A few seconds after releasing the keys, the measured pressure will appear on the display.

* Setting internal parameters.

Next to the adjustment of the setpoint, internal settings can be made like differential, sensor-offset, setpoint range, read out settings and alarm settings.

Push the **DOWN** key for more than 10 seconds, to enter the 'Internal Programming Menu'. In the left display the upper- and lower-segment are blinking. Over the **UP** and **DOWN** keys the required parameter can be selected (see the table for the parameters).

If the required parameter is selected, the value can be read-out by pushing the **SET** key. Push the **UP** or **DOWN** key to change the value of this parameter.

If 20 seconds no key is pushed, the **ALFA 77-PI** changes to the normal operation mode.

* Adjusting pressure sensor.

The **pressure sensor** can be adjusted with the Offset pressure sensor (parameter 04).

Indicates the **ALFA 77-PI** p.e. 2 Pa to much, than the Offset pressure sensor should be lowered with 2 Pa.

If the signal from the pressure sensor fluctuates to much than it can be damped with parameter 05.

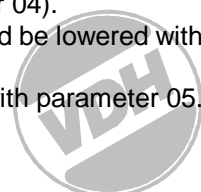

* **Error messages.**

In the display of the **ALFA 77-PI** the following errors can appear:

LO- Minimum alarm.

HI- Maximum alarm.

EE- Settings are lost.

Solution EE: - Reprogram the settings.

* **Alarm function.**

As a failure or alarm occurs an error message is shown in the display and the buzzer (as mounted) will make noise. The **ALFA 77-PI** remembers it's error message, although it is already solved (as parameter P36 is default value '0').

The error message can be reset with the **SET** key (only when parameter P37 is set to 1). If after pressing the **SET** key (=Alarm reset) and the alarm is still not solved, the **ALFA 77-PI** displays the pressure and the error code alternated. Is the alarm solved, the error message disappears and the actual pressure is shown again.

Through parameter 35 the alarm relay function can be changed from (default on fail safe alarm) to control alarm. At control alarm the relay will be activated when an alarm occurs, at fail safe alarm the relay is normally active and in case of alarm the relay falls off (also in case of power failure).

Through parameter P30 you can select the type of alarm: none, absolute or relative alarm. At the function relative alarm, the minimum and maximum alarm settings will be taken relative from the control setpoint.

* **Technical details.**

Type	: ALFA 77-PI MIN/MAX Pressostat
Range	: -99/+999 Pa, (default 0-500 Pa (1) \approx 0-2 "WC)
Supply	: 24 Vac (-5/+10%)
Read out	: 3-digit 7-segments display
Relays	: Ry-1 Out.1 SPST (C,NO) 250V/8A (cos ϕ =1) Ry-2 Out.2 SPDT (C,NO,NC) 250V/8A (cos ϕ =1)
Control	: through push buttons on the front.
Front	: Polycarbonaat IP65
Pressure sensor	: PX25-2 (Supply 24Vac, Signal input 4-20mA).
Dimensions	: 35 x 77 x 71,5mm (hwd)
Panel cut out	: 29 x 70mm (hw)
Accuracy	: \pm 0,5 % from the range.

- Provided with memory protection during power failure.
- Connection with screw terminals at the back side.
- Special versions on request available.



* **Parameters ALFA 77-PI.**

Par.	Description of the Parameter	Range	Default
01	Function relays-1: 0= Not active (C-NO) 1= Maximum Alarm 2= Minimum Alarm	0..2	1
02	Function relais-2: 0= Not active (C-NO-NC) 1= Maximum Alarm 2= Minimum Alarm	0..2	2
03	Function PI output: 1= Raise the pressure 2= Lower the pressure	1..2	1
04	Offset pressure sensor	-20..+20 Pa	0
05	Damping pressure signal	2..20	10
06	Value pressure sensor at 4mA in	-99..+999 Pa	0
07	Value pressure sensor at 20mA in	-99..+999 Pa	500
10	Switching differential minimum alarm	1..15 Pa	1
11	Switching offset minimum alarm	-15..+15 Pa	0
12	Switching differential maximum alarm	1..15 Pa	1
13	Switching offset maximum alarm	-15..+15 Pa	0
14	P-band adjustment (proportional band)	1..15 Pa	5
15	I-time adjustment (integration time)	0..99 Minutes	0 (off)
16	Offset PI (zone)	-15..+15 Pa	0
20	Minimum adjustable setpoint	-99..999 Pa	0
21	Maximum adjustable setpoint	-99..999 Pa	500
30	Alarm mode: 1=Absolute 2=Relative	1..2	1
31	Minimum alarm setpoint	-99..+999 Pa	0
32	Maximum alarm setpoint	-99..+999 Pa	500
33	Time delay minimum alarm	0..99 Minutes	0
34	Time delay maximum alarm	0..99 Minutes	0
35	Relays-1 function: 0= Fail safe alarm 1= Control alarm	0..1	0
36	Relais-2 function: 0= Fail safe alarm 1= Control alarm	0..1	0
37	Reset alarm relays at recovered alarm	0=No, 1=Yes	0
38	Reset alarm relays at manual reset	0=No, 1=Yes	1
40	Control delay after power-failure	0..99 Minutes	0
95	Software version	0..255	-
96	Production year	00..99	-
97	Production week	1..52	-
98	Serial number (x1000)	0..255	-
99	Serial number (units)	0..999	-



* **Dimensions.**

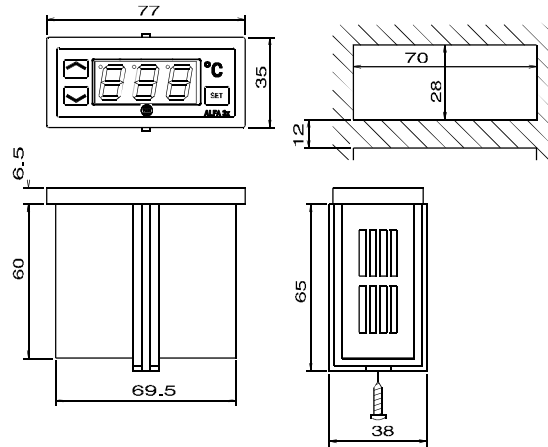

* **Connections.**

ALFA 77-PI (for PX25-2)

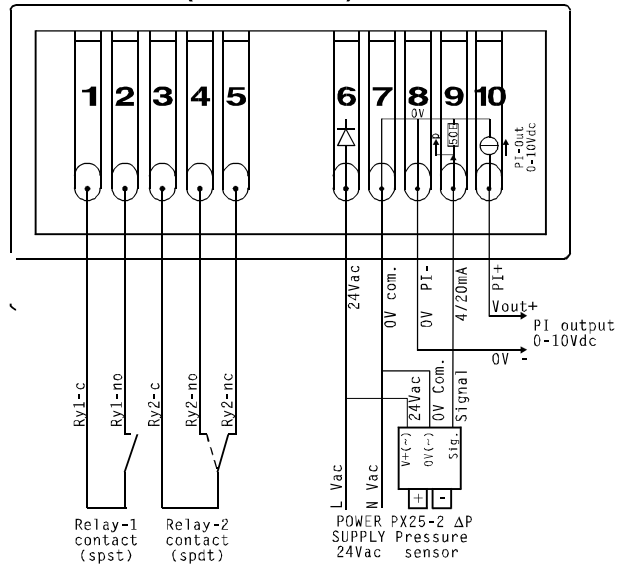

* **Adresse.**

VDH Products BV
Produktieweg 1
9301 ZS Roden
The Netherlands

Tel:
Fax:
Email:
Internet:

+31 (0)50 - 30 28 900
+31 (0)50 - 30 28 980
info@vdhproducts.nl
www.vdhproducts.nl

